

# AN11383

## NTAG21xF, Field detection and sleep mode feature

Rev. 1.0 — 18 July 2013  
270910

Application note  
COMPANY PUBLIC

### Document information

Info	Content
<b>Keywords</b>	NTAG, Field detection pin, Sleep mode
<b>Abstract</b>	It is shown how the field detection pin and its associated sleep mode function can be used on the NTAG21xF-family of tags



## Revision history

Rev	Date	Description
1.0	20130718	Initial revision

## Contact information

For more information, please visit: <http://www.nxp.com>

For sales office addresses, please send an email to: [salesaddresses@nxp.com](mailto:salesaddresses@nxp.com)

## 1. Introduction

This document describes the use of the NTAG213F and NTAG216F (NTAG21xF) field-detection pin as signal for an external circuit – e.g. a microcontroller and the use of this pin as an input to send the NTAG21xF into sleep-mode.

## 2. Field detection circuit

The NTAG21xF has additional to the two antenna pins two extra pins which can be used to signal activity from a NFC-reader to an external circuit. One pin is GND (VSS) and the other is an open-drain output called field-detect (FD).

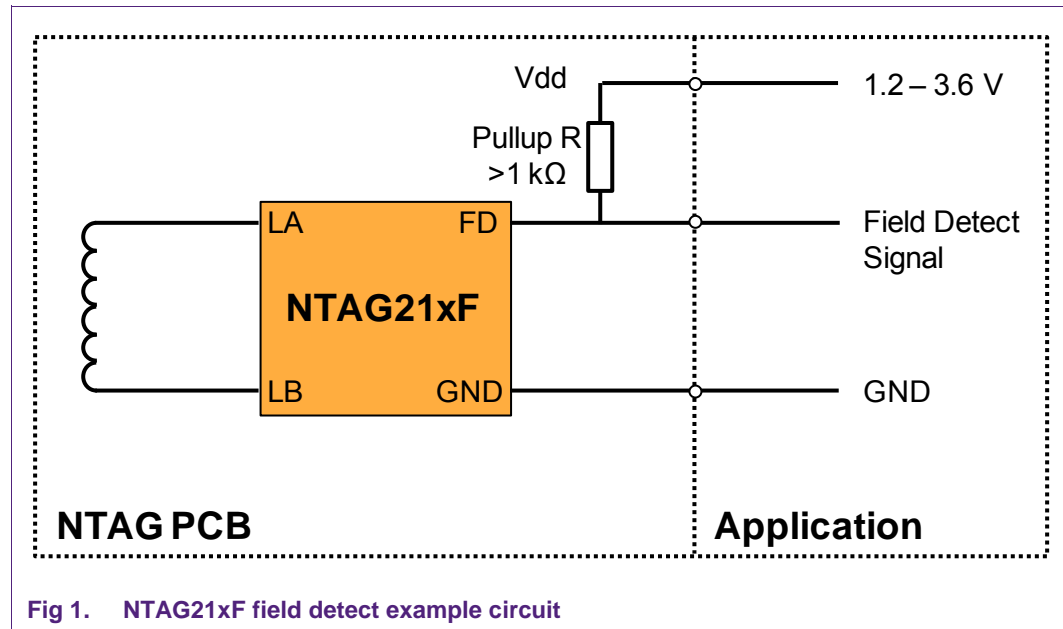

Fig 1. NTAG21xF field detect example circuit

The signal on the field detect pin is digital and set when the configured event occurs. Due to the open drain implementation with an external pullup resistor, the resulting signal is high when field detect is not set and low when field detect is set respectively active. The pullup resistor should have a resistance above 1 kOhm to limit the current through the field detect pin.

## 3. Field detection feature options

The field-detect feature can be configured to react on different events. Whenever this event happens, the field-detect signal is set/activated and stays active until power down of the transponder.

### 3.1 Field detect options

The configuration of the field-detect-pin can be either:

- RF-field On  
When a RF-field is present, field detect is activated.
- Start of Frame  
In ISO14443-A ([1], [2]) every transferred command starts with a special signal called “Start of Frame” (SOF). Here field detect is activated when a valid ISO14443-A SOF is detected.

- State "ACTIVE"  
 In ISO14443-A the first action of a reader is the anticollision loop. After a successful anticollision the tag is in the state "ACTIVE" and is then able to process for example read and write commands on the memory. In Fig 2 the possibilities to reach the state "ACTIVE" are shown.

The field-detect-signal is reset only on a RF-reset or power down of RF-field.

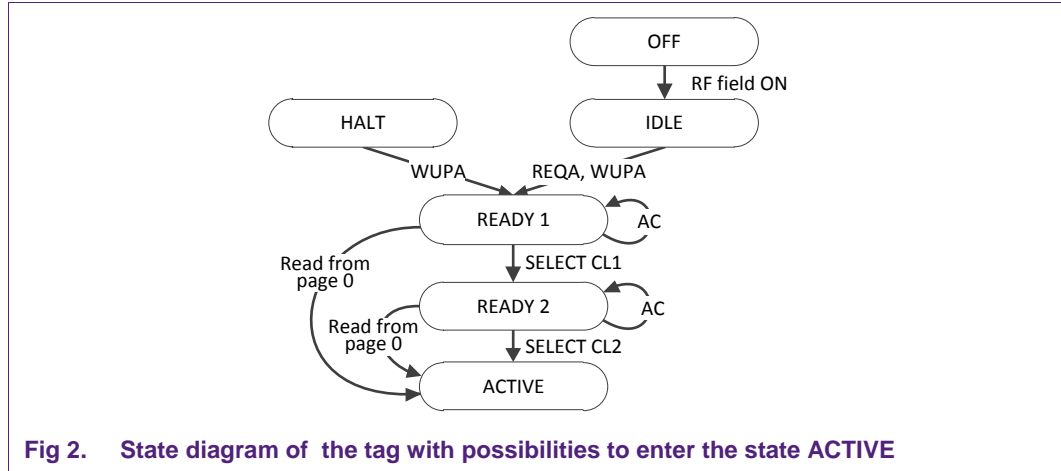

Fig 2. State diagram of the tag with possibilities to enter the state ACTIVE

### 3.2 Timing and signal form

The signal on the field detect pin is digital, it has only two states. The high level is determined by the Vdd voltage on the pullup resistor.

The timing of the different modes is shown in the following graph:

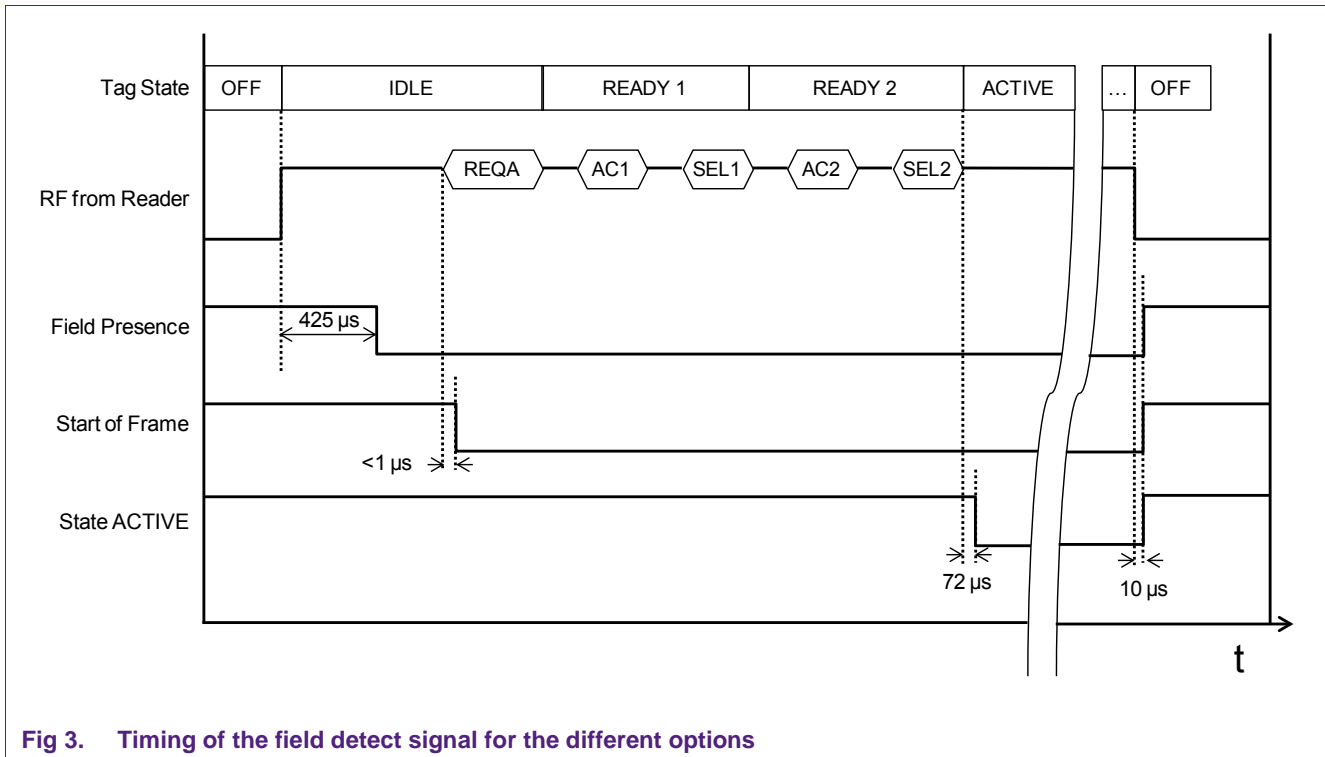

Fig 3. Timing of the field detect signal for the different options

### 4. Sleep mode feature

The sleep mode disables all tag reactions on RF commands. If the tag is in the sleep mode, it cannot be read and not detected by a Reader.

When the feature sleep mode is enabled in the tag-configuration, then applying GND potential (voltage between GND and field detect < 0.8 V) to the field-detect-pin switches the tag to the sleep mode.

The potential on this pin is only sampled on turn-on of the transponder (RF field switch on). So the pin has to be hold on low while switching the field on, otherwise sleep mode is not entered. This mode can only be left with a new power up of the transponder.

If the sleep mode is enabled, caution should be taken to not let the pin floating on startup, because the in this case undefined potential on the pin can cause the sleep mode to be entered unintentionally.

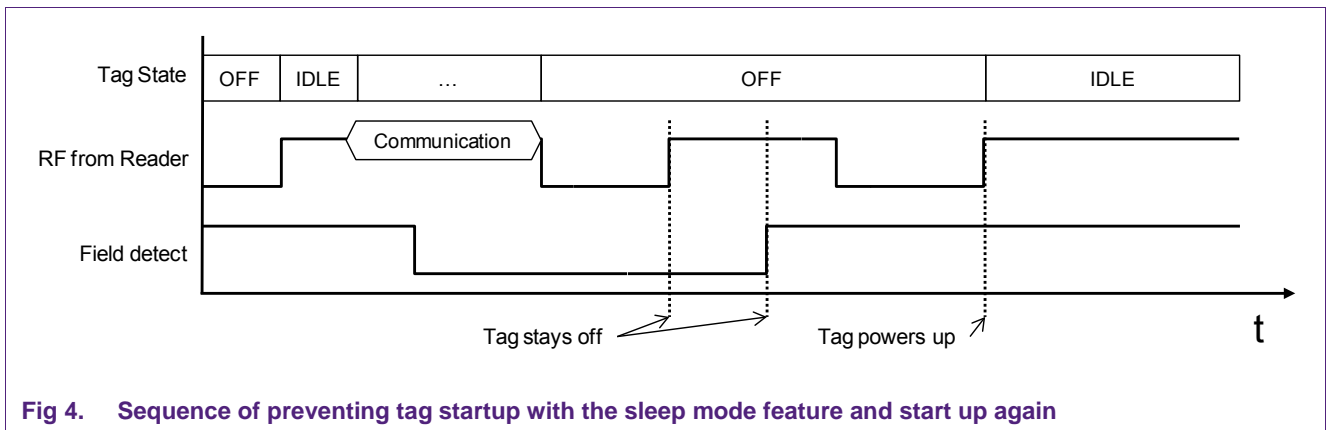

Fig 4. Sequence of preventing tag startup with the sleep mode feature and start up again

## 5. Configuring the field detect and sleep mode feature

The configuration of the field detect pin and the sleep mode is stored in the first byte of the configuration page of the transponder [3]. The configuration page is at the following page-address:

- NTAG213F: page 41 / 29h
- NTAG216F: page 227 / E3h

To set the corresponding option, read the configuration page and write it again with the bits “SLEEP\_EN” and “FDP CONF” from the first byte changed to your needed configuration.

**Table 1. Field detect and sleep mode configuration**

Bit Number							
7	6	5	4	3	2	1	0
MIRROR CONF		MIRROR Byte		SLEEP_EN	STRG MOD_EN	FDP CONF	

The values for “SLEEP\_EN” and “FDP CONF” have the following possibilities:

**Table 2. Explanation of possible settings for field detect and sleep mode**

Field	Bitcount	Default Value	Description
SLEEP_EN	1	0b	Enables the sleep mode function
FDP CONF	2	11b	configuration of the field detect pin 00b ... field detect disabled 01b... enabled by first Start-of-Frame (SoF) 10b... enabled by tag in state “ACTIVE” 11b... enabled by RF-field presence

## 6. References

- [1] ISO/IEC 14443-2:2010, *Identification cards — Contactless integrated circuit cards — Proximity cards — Part 2: Radio frequency power and signal interface*
- [2] ISO/IEC 14443-3:2011, *Identification cards — Contactless integrated circuit cards — Proximity cards — Part 3: Initialization and anticollision*
- [3] Datasheet NTAG213F/216F, *NFC Forum Type 2 Tag compliant IC with 144/888 bytes user memory and field detection*

## 7. Legal information

### 7.1 Definitions

**Draft** — The document is a draft version only. The content is still under internal review and subject to formal approval, which may result in modifications or additions. NXP Semiconductors does not give any representations or warranties as to the accuracy or completeness of information included herein and shall have no liability for the consequences of use of such information.

### 7.2 Disclaimers

**Limited warranty and liability** — Information in this document is believed to be accurate and reliable. However, NXP Semiconductors does not give any representations or warranties, expressed or implied, as to the accuracy or completeness of such information and shall have no liability for the consequences of use of such information.

In no event shall NXP Semiconductors be liable for any indirect, incidental, punitive, special or consequential damages (including - without limitation - lost profits, lost savings, business interruption, costs related to the removal or replacement of any products or rework charges) whether or not such damages are based on tort (including negligence), warranty, breach of contract or any other legal theory.

Notwithstanding any damages that customer might incur for any reason whatsoever, NXP Semiconductors' aggregate and cumulative liability towards customer for the products described herein shall be limited in accordance with the Terms and conditions of commercial sale of NXP Semiconductors.

**Right to make changes** — NXP Semiconductors reserves the right to make changes to information published in this document, including without limitation specifications and product descriptions, at any time and without notice. This document supersedes and replaces all information supplied prior to the publication hereof.

**Suitability for use** — NXP Semiconductors products are not designed, authorized or warranted to be suitable for use in life support, life-critical or safety-critical systems or equipment, nor in applications where failure or malfunction of an NXP Semiconductors product can reasonably be expected to result in personal injury, death or severe property or environmental damage. NXP Semiconductors accepts no liability for inclusion and/or use of NXP Semiconductors products in such equipment or applications and therefore such inclusion and/or use is at the customer's own risk.

**Applications** — Applications that are described herein for any of these products are for illustrative purposes only. NXP Semiconductors makes no representation or warranty that such applications will be suitable for the specified use without further testing or modification.

Customers are responsible for the design and operation of their applications and products using NXP Semiconductors products, and NXP Semiconductors accepts no liability for any assistance with applications or customer product design. It is customer's sole responsibility to determine whether the NXP Semiconductors product is suitable and fit for the customer's applications and products planned, as well as for the planned application and use of customer's third party customer(s). Customers should provide appropriate design and operating safeguards to minimize the risks associated with their applications and products.

NXP Semiconductors does not accept any liability related to any default, damage, costs or problem which is based on any weakness or default in the customer's applications or products, or the application or use by customer's third party customer(s). Customer is responsible for doing all necessary testing for the customer's applications and products using NXP Semiconductors products in order to avoid a default of the applications and the products or of the application or use by customer's third party customer(s). NXP does not accept any liability in this respect.

**Export control** — This document as well as the item(s) described herein may be subject to export control regulations. Export might require a prior authorization from competent authorities.

**Evaluation products** — This product is provided on an "as is" and "with all faults" basis for evaluation purposes only. NXP Semiconductors, its affiliates and their suppliers expressly disclaim all warranties, whether express, implied or statutory, including but not limited to the implied warranties of non-infringement, merchantability and fitness for a particular purpose. The entire risk as to the quality, or arising out of the use or performance, of this product remains with customer.

In no event shall NXP Semiconductors, its affiliates or their suppliers be liable to customer for any special, indirect, consequential, punitive or incidental damages (including without limitation damages for loss of business, business interruption, loss of use, loss of data or information, and the like) arising out of the use of or inability to use the product, whether or not based on tort (including negligence), strict liability, breach of contract, breach of warranty or any other theory, even if advised of the possibility of such damages.

Notwithstanding any damages that customer might incur for any reason whatsoever (including without limitation, all damages referenced above and all direct or general damages), the entire liability of NXP Semiconductors, its affiliates and their suppliers and customer's exclusive remedy for all of the foregoing shall be limited to actual damages incurred by customer based on reasonable reliance up to the greater of the amount actually paid by customer for the product or five dollars (US\$5.00). The foregoing limitations, exclusions and disclaimers shall apply to the maximum extent permitted by applicable law, even if any remedy fails of its essential purpose.

### 7.3 Licenses

#### Purchase of NXP ICs with NFC technology

Purchase of an NXP Semiconductors IC that complies with one of the Near Field Communication (NFC) standards ISO/IEC 18092 and ISO/IEC 21481 does not convey an implied license under any patent right infringed by implementation of any of those standards.

### 7.4 Trademarks

Notice: All referenced brands, product names, service names and trademarks are property of their respective owners.

**MIFARE** — is a trademark of NXP B.V.

## 8. Contents

---

1.	<b>Introduction .....</b>	<b>3</b>
2.	<b>Field detection circuit .....</b>	<b>3</b>
3.	<b>Field detection feature options .....</b>	<b>3</b>
3.1	Field detect options .....	3
3.2	Timing and signal form .....	4
4.	<b>Sleep mode feature .....</b>	<b>5</b>
5.	<b>Configuring the field detect and sleep mode feature .....</b>	<b>6</b>
6.	<b>References .....</b>	<b>6</b>
7.	<b>Legal information .....</b>	<b>7</b>
7.1	Definitions .....	7
7.2	Disclaimers.....	7
7.3	Licenses .....	7
7.4	Trademarks .....	7
8.	<b>Contents.....</b>	<b>8</b>

---

Please be aware that important notices concerning this document and the product(s) described herein, have been included in the section 'Legal information'.

---

© NXP B.V. 2013.

All rights reserved.

For more information, visit: <http://www.nxp.com>

For sales office addresses, please send an email to: [salesaddresses@nxp.com](mailto:salesaddresses@nxp.com)

Date of release: 18 July 2013

270910

Document identifier: AN11383