



# High-Speed CAN Transceiver with Standby Mode

## TJA1040T

Last Updated: Aug 16, 2023

The TJA1040 is the interface between the controller area network (CAN) protocol controller and the physical bus. It is primarily intended for high speed applications, up to 1 MBaud, in passenger cars. The device provides differential transmit capability to the bus and differential receive capability to the CAN controller.

The TJA1040 is the next step up from the TJA1050 high speed CAN transceiver. Being pin compatible and offering the same excellent EMC performance, the TJA1040 also features:

- An ideal passive behavior when supply voltage is off
- A very low-current standby mode with remote wake-up capability via the bus.

This makes the TJA1040 an excellent choice in nodes, which can be in power down or standby mode in partially powered networks.

## TJA1040T Block Diagram

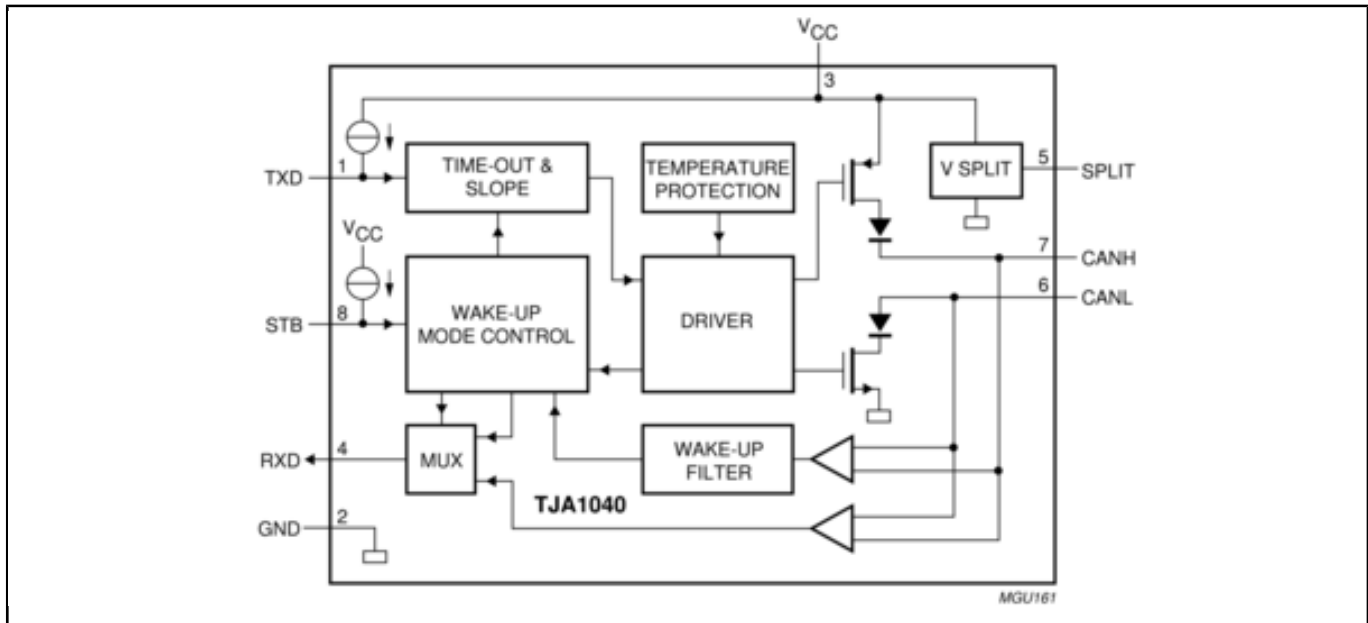

View additional information for [High-Speed CAN Transceiver with Standby Mode](#).

Note: The information on this document is subject to change without notice.

**www.nxp.com**

NXP and the NXP logo are trademarks of NXP B.V. All other product or service names are the property of their respective owners. The related technology may be protected by any or all of patents, copyrights, designs and trade secrets. All rights reserved. © 2024 NXP B.V.