

Motor Control Demonstration System

using the 56F8013 Demonstration Board

User Guide

56F8000

16-bit Digital Signal Controllers

56F8013MCSUG

Rev. 1

08/2005

freescale.com

Document Revision History

Version History	Description of Change
Rev. 0	Initial Release
Rev. 1	Changing T3 to T1 on page 27 of schematics

TABLE OF CONTENTS

Preface 1-vii

Chapter 1 Introduction

1.1	Motor Control Demonstration System Architecture	1-1
-----	---	-----

Chapter 2 Technical Summary

2.1	Brushless Motor	2-2
2.2	Motor Connector	2-3
2.3	Daughter Card Connector	2-4
2.4	Motor Bus Voltage Feedback	2-5
2.5	Motor Bus Current Feedback	2-5
2.6	Back-EMF / Zero-Crossing Feedback	2-5
2.7	Hall-Effect / Zero-Crossing Selector	2-5
2.8	Debug LED Option	2-6
2.9	Power Supply	2-6
2.10	Test Points	2-6

Appendix A Motor Control Schematics

Appendix B Motor Control Bill of Material

LIST OF FIGURES

1-1	Connection of the 56F8000 Motor Control & 56F8013 Demonstration Boards. . . .	1-2
1-2	Connecting the Motor Control Demonstration System	1-2

LIST OF TABLES

	Document Revision History	1-2
2-1	Motor Information	2-2
2-2	Motor Interface Connector Description	2-3
2-3	Daughter Card Connector Description	2-4
2-4	Hall-Effect / Zero-Crossing Selector Options	2-6

Preface

This reference manual describes the hardware on the 56F8000 Motor Control Board in detail.

Audience

This document is intended for application developers who are creating software for devices using the Freescale 56F8000 Motor Control Board or a member of the 56F801x family.

Organization

This manual is organized into two chapters and two appendixes.

- **Chapter 1, Introduction**, provides an overview of the Demonstration Board and its features.
- **Chapter 2, Technical Summary**, describes in detail the 56F8000 Motor Control Board hardware.
- **Appendix A, Motor Control Schematics**, contains the schematics of the 56F8000 Motor Control board.
- **Appendix B, Motor Control Bill of Material**, provides a list of the materials used on the 56F8000 Motor Control Board.

Suggested Reading

More documentation on the 56F8000 Motor Control Board and the 56F8013 Demonstration Board may be found at URL:

www.freescale.com

Notation Conventions

This manual uses the following notational conventions:

Term or Value	Symbol	Examples	Exceptions
Active High Signals (Logic One)	No special symbol attached to the signal name	A0 CLKO	
Active Low Signals (Logic Zero)	Noted with an overbar in text and in most figures	\overline{WE} \overline{OE}	In schematic drawings, Active Low Signals may be noted by a backslash: $\backslash WE$
Hexadecimal Values	Begin with a "\$" symbol	\$0FF0 \$80	
Decimal Values	No special symbol attached to the number	10 34	
Binary Values	Begin with the letter "b" attached to the number	b1010 b0011	
Numbers	Considered positive unless specifically noted as a negative value	5 -10	Voltage is often shown as positive: +3.3V
Blue Text	Linkable on-line	...refer to Chapter 7, License	
Bold	Reference sources, paths, emphasis	...see: http://www.freescale.com/	

Definitions, Acronyms, and Abbreviations

Definitions, acronyms and abbreviations for terms used in this document are defined below for reference.

A/D	Analog-to-Digital; a method of converting Analog signals to Digital values
ADC	Analog-to-Digital Converter; a peripheral on the 56F801x processor
56F801x	A family of processors with motor control peripherals
EMF	Electro-Motive Force
EOnCE™	Enhanced On-Chip Emulation; a debug bus and port was created to enable a designer to create a low-cost hardware interface for a professional-quality debug environment
Demo Board	Demonstration Board; a hardware platform which allows a customer to evaluate the silicon and develop his application
GPIO	General Purpose Input and Output port on Freescale's family of controllers; does not share pin functionality with any other peripheral on the chip and can only be set as an input, output, or level-sensitive interrupt input
IC	Integrated Circuit
JTAG	Joint Test Action Group; a bus protocol/interface used for test and debug
LED	Light Emitting Diode
OnCE™	On-Chip Emulation, a debug bus and port created to allow a means for low-cost hardware to provide a professional-quality debug environment
PCB	Printed Circuit Board
PWM	Pulse Width Modulation

References

The following sources were referenced to produce this manual:

- [1] *DSP56800E Reference Manual*, DSP56800ERM, Freescale Semiconductor, Inc.
- [2] *56F8000 Peripheral Reference Manual*, MC56F8000RM, Freescale Semiconductor, Inc.
- [3] *56F8013 Technical Data*, MC56F8013, Freescale Semiconductor, Inc.

Chapter 1

Introduction

The 56F8000 Motor Control Board is used to demonstrate the motor control abilities of the 56F8013 processor and to provide a hardware tool allowing the development of applications.

1.1 Motor Control Demonstration System Architecture

The Motor Control Demonstration System is a combination of the 56F8000 Motor Control Board and a 56F8013 Demonstration Board, as shown in [Figure 1-1](#). This combination of boards provides a 56F8013 part, small brushless DC motor, Hall-Effect sensors, RS-232 interface, user LEDs and user pushbutton switches.

The Motor Control Demonstration System is designed to provide a ready-made software development platform for small brushless DC motors. The motor may be controlled by its Hall-Effect sensors or by sensorless techniques. The Motor Control Demonstration System can be used to develop real-time software and hardware products. The Motor Control Demonstration System provides the features necessary for a user to write and debug software and to demonstrate the functionality of that software.

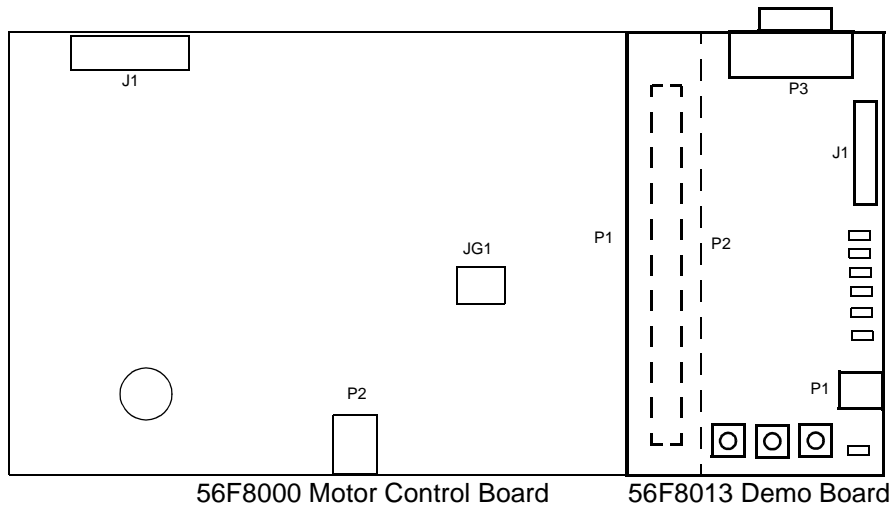

Figure 1-1. Connection of the 56F8000 Motor Control & 56F8013 Demonstration Boards

An interconnection diagram is shown in [Figure 1-2](#) for connecting the PC, the external +9.0V DC power supply, the 56F8000 Motor Control Board and the 56F8013 Demonstration Board.

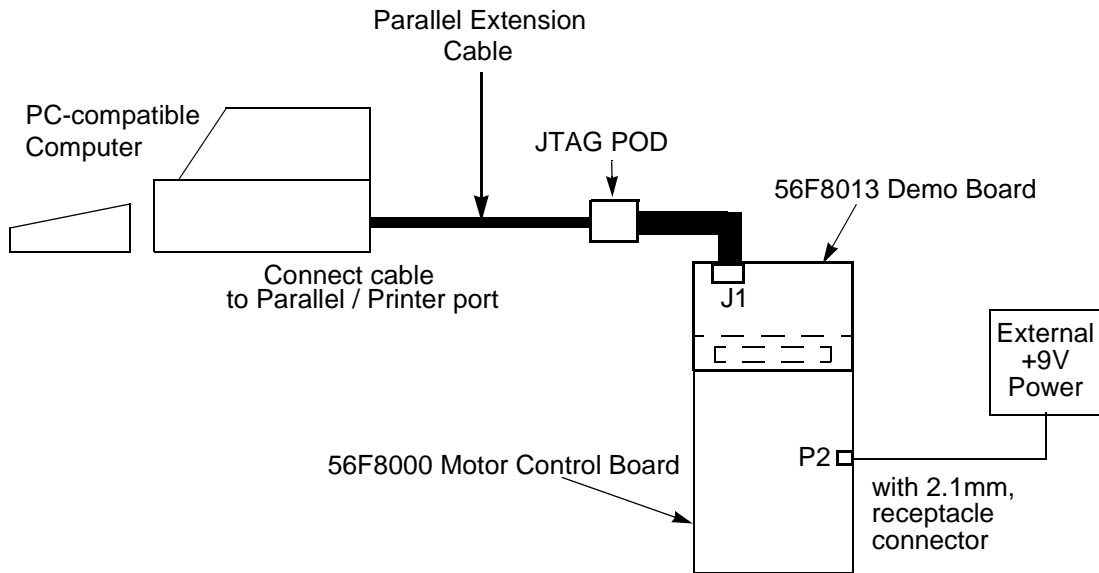

Figure 1-2. Connecting the Motor Control Demonstration System

Perform the following steps to connect the Motor Control Demonstration System:

1. Connect the 56F8013 Demonstration Board to the 56F8000 Motor Control Board by pressing the two together, using P2 on the Demonstration Board and P1 on the Motor Control Board
2. Connect the parallel extension cable to the Parallel port of the host computer
3. Connect the other end of the parallel extension cable to the JTAG interface POD.
 - Connect the ribbon cable from the JTAG interface POD to J1 on the 56F8013 Demonstration Board as shown in [Figure 1-2](#), which provides the connection allowing the host computer to control the board
4. Make sure that the external +9V DC, 450mA power supply is **not** plugged into a +120V AC power source
5. Connect the 2.1mm output power plug from the external power supply into P2 on the 56F8000 Motor Control Board as shown in [Figure 1-2](#).
6. Apply power to the external power supply
The green Power-ON LED, LED7 on the 56F8013 Demonstration Board and LED1 on the 56F8000 Motor Control Board, will illuminate when power is correctly applied.

NOTE: *Since the 56F8013 Demonstration Board is powered by the 56F8000 Motor Control Board, the power connection, P1, on the 56F8013 Demonstration Board is not used in this arrangement.*

Chapter 2

Technical Summary

The 56F8000 Motor Control Board is designed to be combined with the 56F8013 Demonstration Board. This combination provides a software development platform that allows brushless DC motor algorithms to be written and tested without the need to design and build a power stage. This platform supports the development of algorithms that use Hall-Effect sensors and Back-EMF signals for sensorless control.

The main features of the 56F8000 Motor Control Board, with board and schematic reference designators, include:

- Brushless Motor, Maxon EC-200187, 6W 9V [M1]
- Motor interface connector [J1]
- Input power connector [P2]
- Daughter Card connector, to allow the connection of the 56F8013 Demonstration Board [P1]
- LED power indicator [LED1]
- Motor Bus Voltage sense logic [R39, R40, R47]
- Motor Bus Current sense logic [R57, U2]
- Back EMF Phase Voltage sense logic [R48-R56]
- Zero-Crossing logic [U1]
- Hall-Effect/Zero-Crossing Selector [JG1]
- 3-Phase H-Bridge Power stage [Q1-Q9]
- Power regulation logic [U4]
- (Optional) Five on-board real-time user debugging LEDs [LED2-6]

2.1 Brushless Motor

The 56F8000 Motor Control Board uses a Maxon EC-200187, designated as M1 on the board. The motor characteristics are listed in [Table 2-1](#). For additional information, refer to the Maxon web site: www.maxonmotorusa.com

Table 2-1. Motor Information

M1		
Characteristic	Typical Value	Units
Power Rating	6	W
Nominal Voltage	9.0	Volt
No-Load Speed	8600	rpm
Stall Torque	20	mNm
Speed / Torque Gradient	479.0	rpm / mNm
No-Load Current	110	mA
Terminal Resistance Phase-to-Phase	4.50	Ohm
Maximum Permissible Speed	12000	rpm
Maximum Continuous Current at 5000rpm	1.03	A
Maximum Continuous Torque at 5000rpm	8.70	mNm
Maximum Efficiency	60.0	%
Torque Constant	9.5	mNm / A
Speed Constant	1007	rpm / v
Mechanical Time Constant	70.0	ms
Rotor Inertia	13.9	gcm ²
Terminal Inductance Phase-to-Phase	1.070	mH
Thermal Resistance Housing Ambient	6.8	K / W
Thermal Resistance Winding-Housing	7.4	K / W
Thermal Time Constant Windings	3.7	s
Thermal Time Constant Stator	16.1	s

2.2 Motor Connector

The 56F8000 Motor Control Board provides an interface connector, J1, for the brushless motor. This is a 12-position 1mm FFC/FPC connector, Waldom/Molex 52207-1290. This connector provides the power for the three phases of the motor and the Hall-Effect sensor signals. The pin-out of connector J1 is listed in [Table 2-2](#).

Table 2-2. Motor Interface Connector Description

J1	
Pin #	Signal
1	Phase 1 power
2	Phase 1 power
3	Phase 2 power
4	Phase 2 power
5	Phase 3 power
6	Phase 3 power
7	Ground
8	Hall Sensor 2
9	Hall Sensor 1
10	Hall Sensor3
11	+9.0V
12	No Connection

2.3 Daughter Card Connector

The Daughter Card connector, P1, allows the connection of the 56F8013 Demonstration Board to the 56F8000 Motor Control Board. The Daughter Card connector is a 40-pin 0.1” pitch connector with signals for the PWM, ADC and GPIO peripheral ports. [Table 2-3](#) shows the Daughter Card connector’s signal-to-pin assignments.

Table 2-3. Daughter Card Connector Description

P1			
Pin #	Signal	Pin #	Signal
1	+3.3V	2	NC
3	GND	4	GPIOA7 / $\overline{\text{RESET}}$ / V_{PP}
5	GPIOB7 / TXD / SCL	6	NC
7	GPIOB6 / RXD / SDA / CLKIN	8	NC
9	GPIOA0 / PWM0	10	GPIOC0 / ANA0
11	GPIOA1 / PWM1	12	GPIOC1 / ANA1
13	GPIOB4 / T0 / CLK0	14	GPIOC2 / V_{REFH} / ANA2
15	GPIOB5 / T1 / FAULT3	16	NC
17	GPIOB3 / MOSI / T3	18	GPIOC4 / ANB0
19	GPIOB2 / MISO / T2	20	GPIOC5 / ANB1
21	GPIOB0 / SCLK / SCL	22	GPIOC6 / V_{REFL} / ANB2
23	GPIOB1 / $\overline{\text{SS}}$ / SDA	24	NC
25	GPIOD0 / TDI	26	GPIOB1 / $\overline{\text{SS}}$ / SDA
27	GPIOD1 / TDO	28	GPIOB0 / SCLK / SCL
29	GPIOD2 / TCK	30	GPIOA2 / PWM2
31	GPIOD3 / TMS	32	GPIOA3 / PWM3
33	GPIOA6 / FAULT0	34	GPIOA4 / PWM4 / FAULT1 / T2
35	NC	36	GPIOA5 / PWM5 / FAULT2 / T3
37	NC	38	NC
39	NC	40	NC

2.4 Motor Bus Voltage Feedback

Signal conditioning on the 56F8000 Motor Control Board provides a Motor Bus Voltage feedback signal proportional to the Motor Bus Voltage; refer to [Figure A-2](#). The Motor Bus Voltage is scaled down by a voltage divider consisting of R39, R47, and R40. These values are chosen such that a +9V maximum Motor Bus Voltage corresponds to +3.3V, which is the maximum input level for the Analog-to-Digital Converter on the 56F8013 Demonstration Board.

2.5 Motor Bus Current Feedback

A Motor Bus Current feedback signal proportional to the Motor Bus Current is sampled by resistor R57 and amplified to provide a usable A/D input; refer to [Figure A-2](#). This circuit provides a voltage output with a gain of 8.26 and a voltage offset of +1.65V, allowing the measurement of positive and negative currents. A negative 1A of current would result in an output voltage of 0V; 0A would produce an output of +1.65V, and a positive 1A would result in an output voltage of +3.3V. The equation for the Motor Bus Current feedback measurement is:

$$V_{\text{out}} = (\text{MotorCurrent} * 1.65) + 1.65 \text{ (Volts)}$$

This circuit only measures the current, it does not limit the current. All current limiting for this board must be performed in the controller algorithms.

2.6 Back-EMF / Zero-Crossing Feedback

The Back-EMF and Zero-Crossing feedback signals support Brushless DC motor sensorless algorithms.

For Back-EMF signal conditioning, each motor phase voltage is scaled down by a voltage divider to produce a maximum +3.3V signal for the processor's A/D input; refer to [Figure A-2](#). The input phase voltage signal is scaled based on a maximum of +9V.

For Zero-Crossing signal conditioning, each motor phase voltage is compared with the motor's bus voltage; refer to [Figure A-3](#). When the phase voltage is greater than half the Motor Bus Voltage, the output of the comparator is +3.3V. When the phase voltage is less than half the Motor Bus Voltage, the output of the caparator is +0V.

2.7 Hall-Effect / Zero-Crossing Selector

The 56F8000 Motor Control Board provides a Hall-Effect / Zero-Crossing selector, JG1. The selector allows the user to choose either the three Hall-Effect sensors or the three Zero-Crossing

signals; see [Table 2-4](#). The selected signals are used by the 56F8013 Demonstration Board as inputs on its T0-T2 ports; refer to [Figure A-4](#).

Table 2-4. Hall-Effect / Zero-Crossing Selector Options

JG1			
Zero-Crossing		Hall-Effect	
Pin #	Signal	Pin #	Signal
1 - 2	Zero-Crossing Phase C to T2	2 - 3	Hall Sensor 3 to T2
4 - 5	Zero-Crossing Phase A to T0	5 - 6	Hall Sensor 1 to T0
7 - 8	Zero-Crossing Phase B to T1	8 - 9	Hall Sensor 2 to T1

2.8 Debug LED Option

As an option, five low-current LEDs can be installed on the board to allow real-time program debugging. These LEDs allow the programmer to monitor program execution without having to stop the program during debugging; refer to [Figure A-1](#). Setting GPIOB0, GPIOB1, GPIOB5, GPIOA6, or GPIOC2 to a Logic Zero value will turn on the associated LED.

2.9 Power Supply

The main power input to the 56F8000 Motor Control Board, +9V DC at 450mA, is through a 2.1mm coax power jack, P2. This input power passes through a reverse power-blocking diode to provide a DC supply input for the +3.3V voltage regulator, U4, and the motor. This is the power supply provided with the 56F8013 Demonstration Board Kit, which requires less than 200mA; the remaining current is available for the 56F8000 Motor Control Board. The 56F8000 Motor Control Board provides +3.3V DC voltage regulation for the processor, ADC, JTAG interface and supporting logic; refer to [Figure A-6](#). Additional voltage regulation logic is provided on the 56F8013 Demonstration Board to create a low-noise +3.3V DC voltage to the processor's A/D peripheral. Power applied to the 56F8000 Motor Control Board is indicated with a Power-ON LED, referenced as LED1.

2.10 Test Points

The 56F8000 Motor Control board has two test points:

- +3.3V, TP1
- Digital Ground (GND), TP2

Appendix A

56F8000 Motor Control Schematics

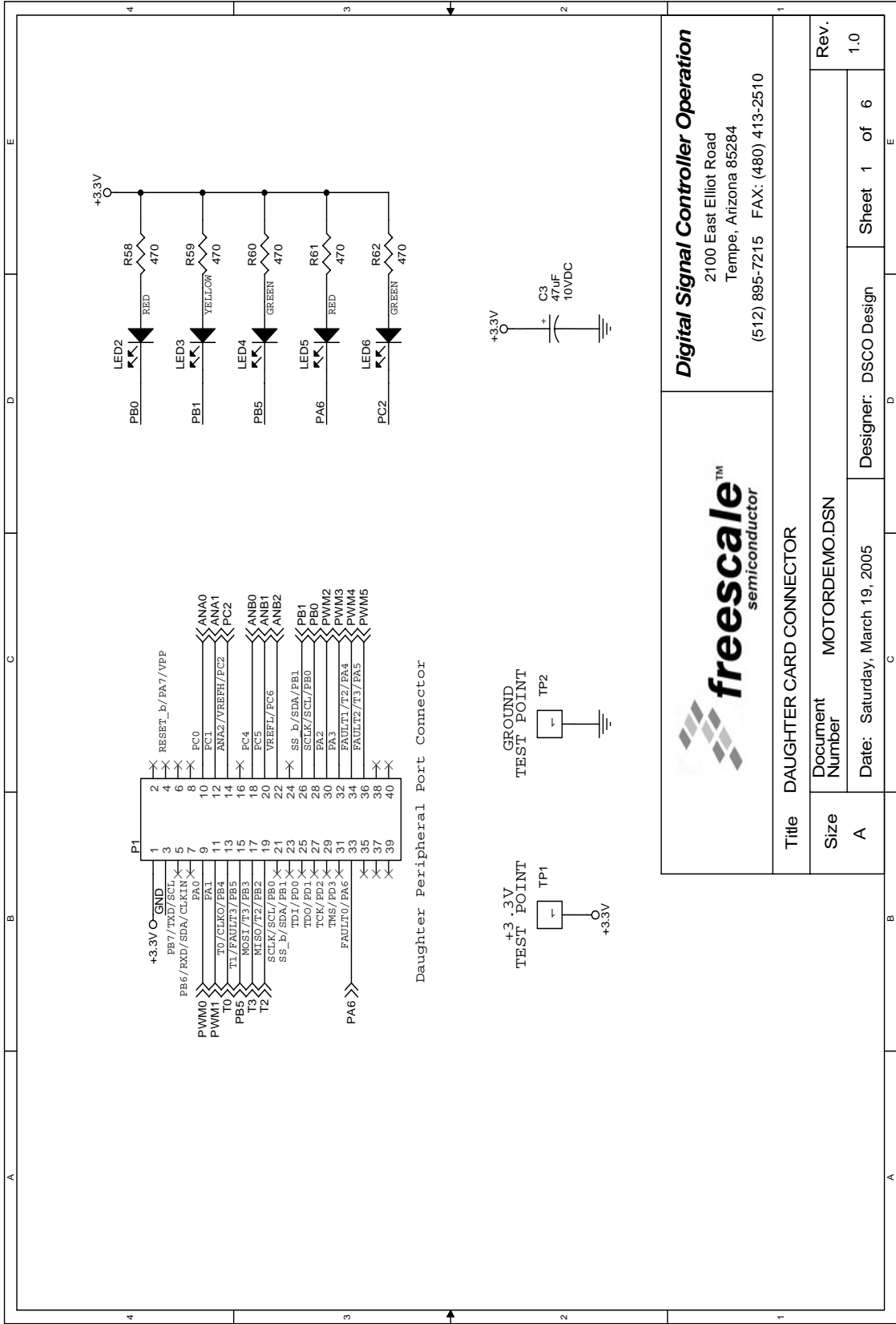
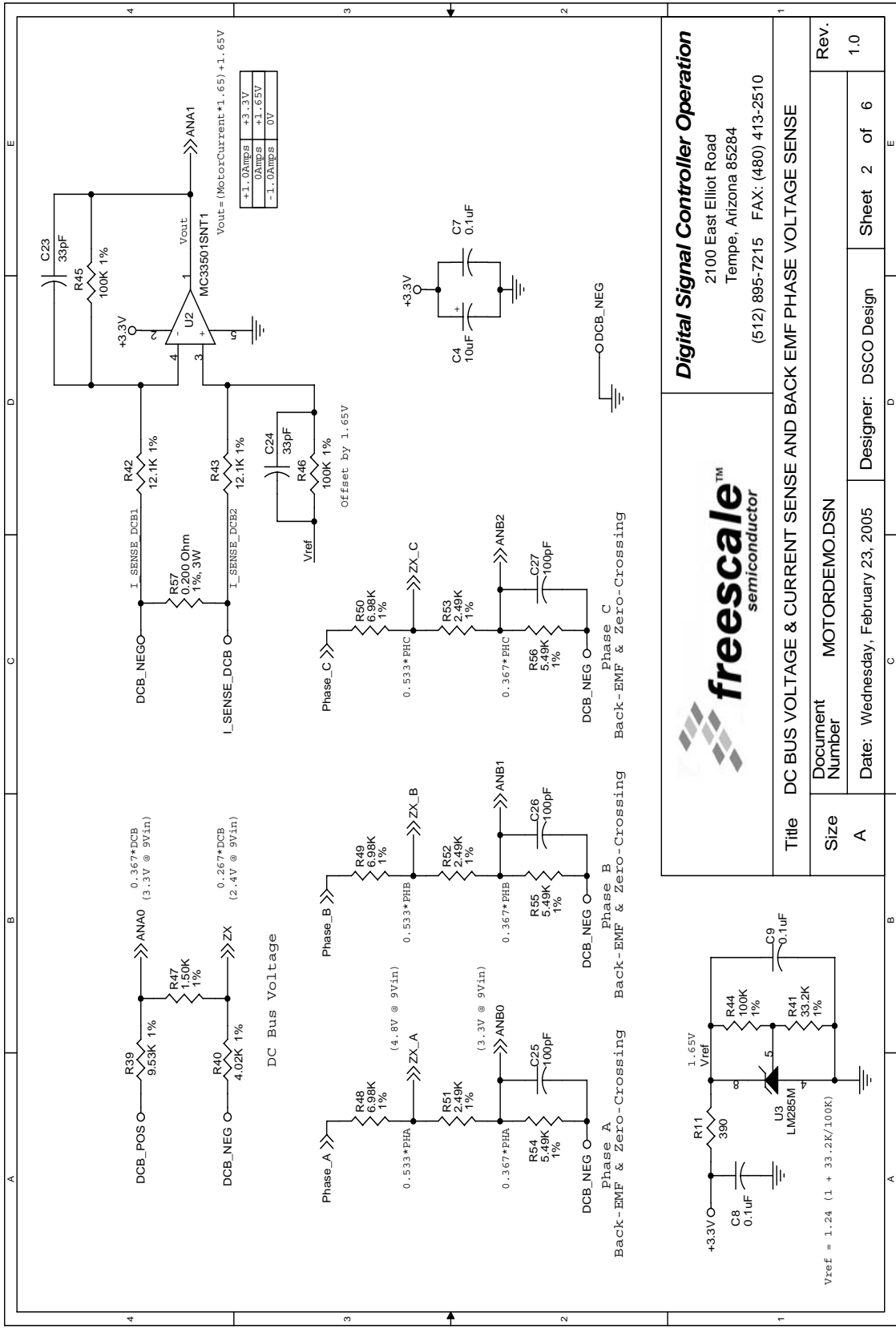

Figure A-1. Daughter Card Connector

freescale™
semiconductor

Digital Signal Controller Operation
2100 East Elliot Road
Tempe, Arizona 85284
(512) 895-7215 FAX: (480) 413-2510

Title DAUGHTER CARD CONNECTOR	
Size A	Document Number MOTORDEMO.DSN
Date: Saturday, March 19, 2005	Designer: DSCO Design
Sheet 1 of 6	Rev. 1.0



freescale™
semiconductor

Digital Signal Controller Operation
2100 East Elliot Road
Tempe, Arizona 85284
(512) 895-7215 FAX: (480) 413-2510

DC BUS VOLTAGE & CURRENT SENSE AND BACK EMF PHASE VOLTAGE SENSE

Document Number: MOTORDEMO.DSN

Date: Wednesday, February 23, 2005

Designer: DSCO Design

Sheet 2 of 6

Rev. 1.0

Figure A-2. DC Bus Voltage and Current Sense and Back-EMF Phase Voltage Sense

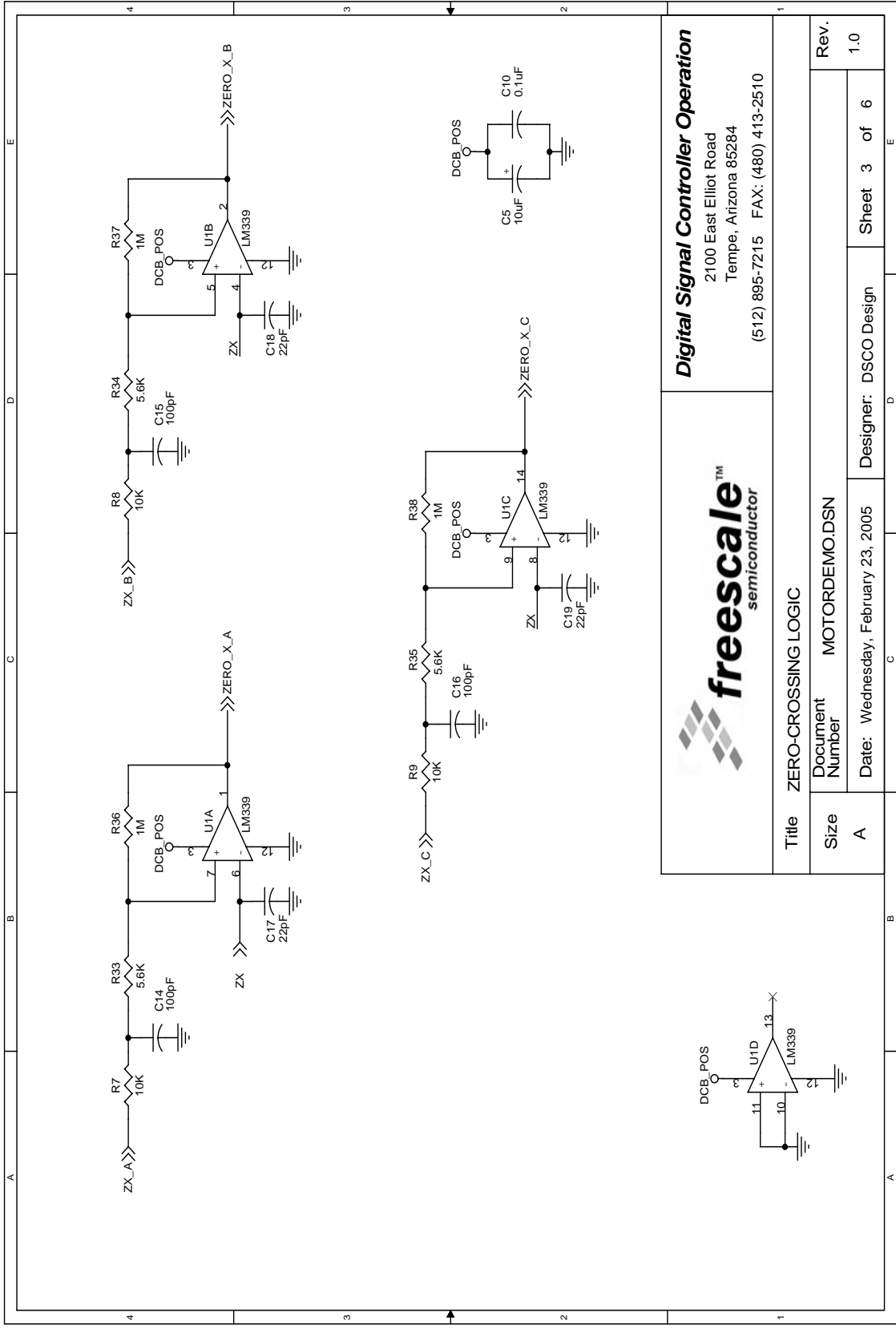

freescale™
semiconductor

Digital Signal Controller Operation
2100 East Elliot Road
Tempe, Arizona 85284
(512) 895-7215 FAX: (480) 413-2510

Title ZERO-CROSSING LOGIC	
Document Number MOTORDEMO.DSN	Rev. 1.0
Date: Wednesday, February 23, 2005	Designer: DSCO Design
Sheet 3 of 6	

Figure A-3. Zero-Crossing Logic

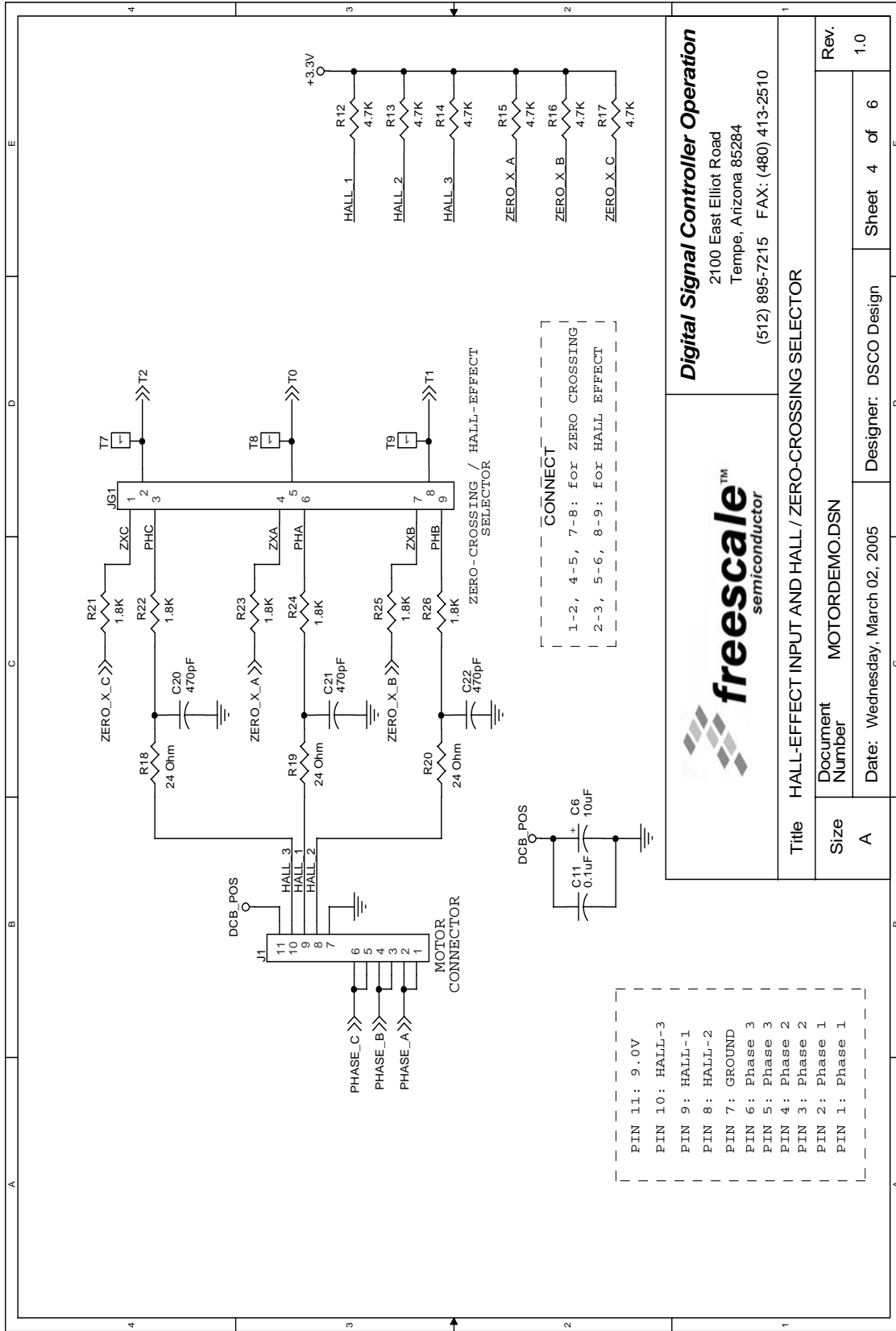

freescale™
semiconductor

Digital Signal Controller Operation
2100 East Elliot Road
Tempe, Arizona 85284
(512) 895-7215 FAX: (480) 413-2510

Title		HALL-EFFECT INPUT AND HALL / ZERO-CROSSING SELECTOR	
Document Number	MOTORDEMO.DSN		
Date:	Wednesday, March 02, 2005	Designer:	DSCO Design
Size	A	Sheet	4 of 6
Rev.	1.0		

Figure A-4. Hall-Effect Input and Hall / Zero-Crossing Selector

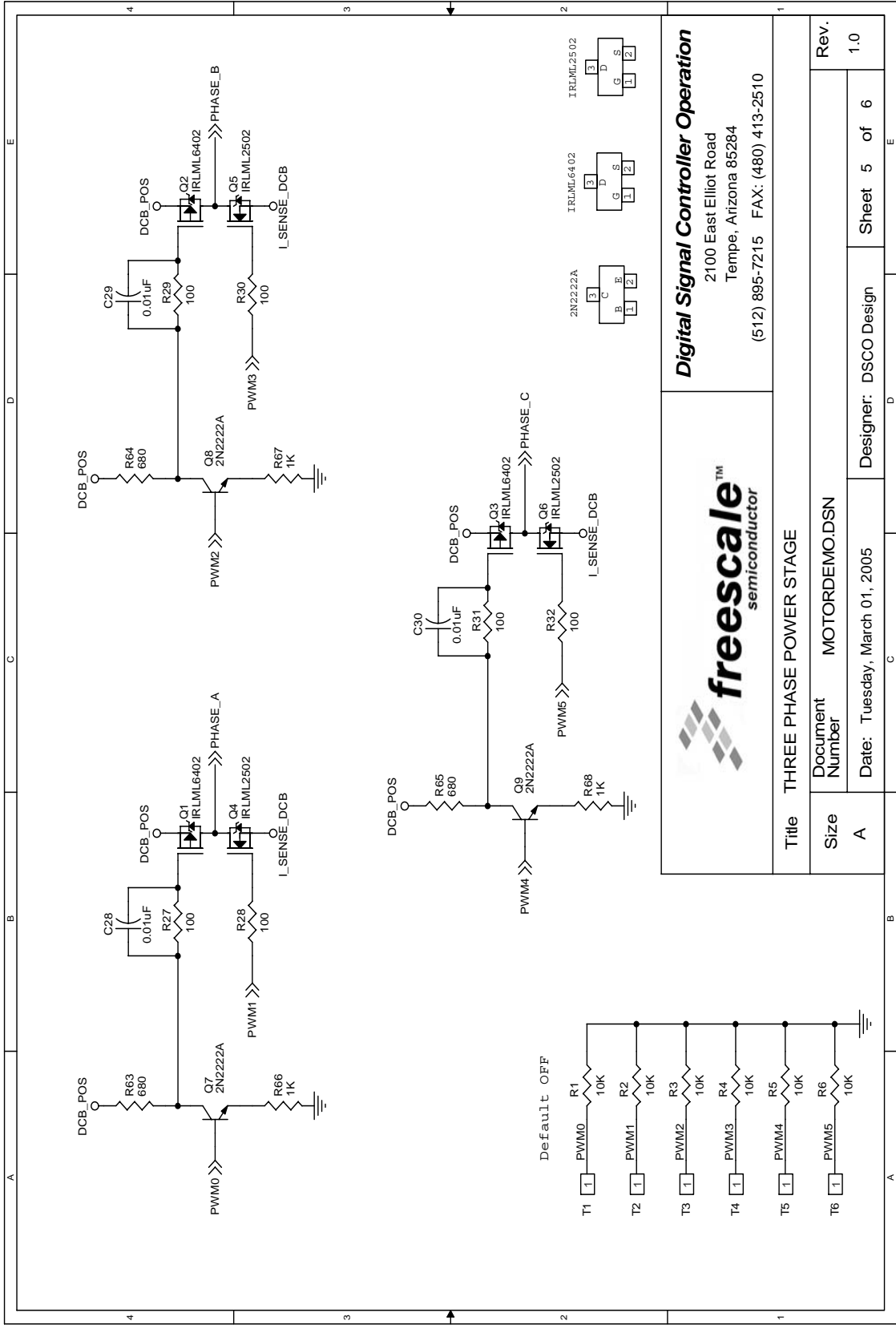

freescale™
semiconductor

Digital Signal Controller Operation
2100 East Elliot Road
Tempe, Arizona 85284
(512) 895-7215 FAX: (480) 413-2510

Title THREE PHASE POWER STAGE	
Document Number MOTORDEMO.DSN	Rev. 1.0
Date: Tuesday, March 01, 2005	Designer: DSCO Design Sheet 5 of 6

Figure A-5. 3-Phase Power Stage

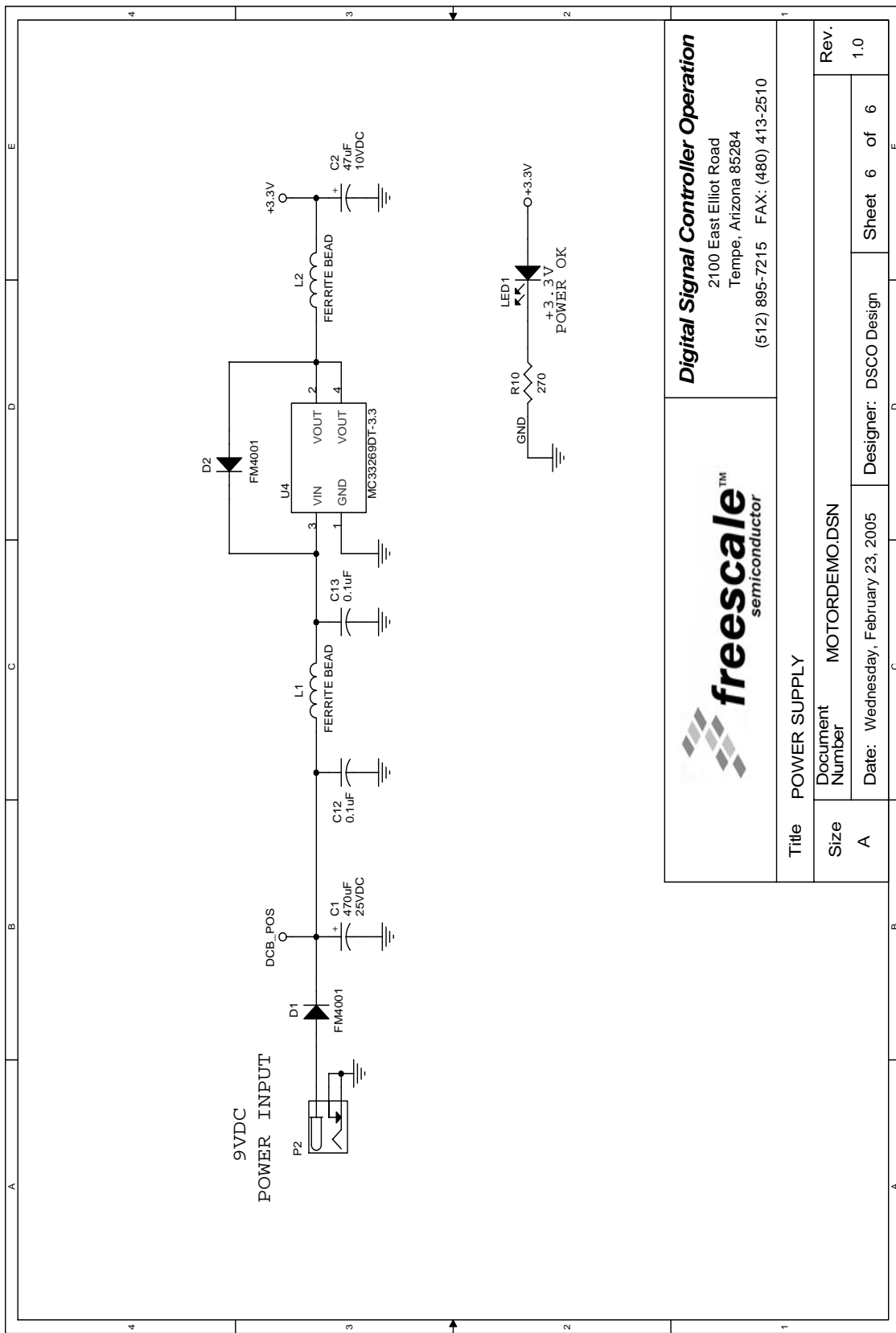

Digital Signal Controller Operation
 2100 East Elliot Road
 Tempe, Arizona 85284
 (512) 895-7215 FAX: (480) 413-2510

Title POWER SUPPLY	
Document Number	MOTORDEMO.DSN
Date:	Wednesday, February 23, 2005
Designer:	DSCO Design
Sheet	6 of 6
Rev.	1.0

Figure A-6. Power Supply

Appendix B

56F8000 Motor Control Bill of Material

Qty	Description	Ref. Designators	Vendor Part #
Motor			
1	Brushless DC Motor	M1	Maxon, EC-200187
Integrated Circuits			
1	Voltage Comparitor	U1	National Semiconductor, LM339AM
1	Op Amp	U2	ON Semiconductor, MC33501SNT1
1	Voltage Reference	U3	National Semiconductor, LM285M
1	+3.3V Voltage Regulator	U4	ON Semiconductor, MC33269DTRK-3
Resistors			
9	10K Ω , 5%, 0805	R1 ,R2, R3, R4, R5, R6, R7, R8, R9	SMEC, RC73L2A103JT
1	270 Ω , 5%, 0805	R10	SMEC, RC73L2A271JT
1	390 Ω , 5%, 0805	R11	SMEC, RC73L2A391JT
6	4.7K Ω , 5%, 0805	R12, R13, R14, R15, R16, R17	SMEC, RC73L2A472JT
3	24 Ω , 5%, 0805	R18, R19, R20	SMEC, RC73L2A240JT
6	1.8K Ω , 5%, 0805	R21, R22, R23, R24, R25, R26	SMEC, RC73L2A182JT
6	100 Ω , 5%, 0805	R27, R28, R29, R30, R31, R32	SMEC, RC73L2A101JT
3	5.6K Ω , 5%, 0805	R33, R34, R35	SMEC, RC73L2A562JT
3	1M Ω , 5%, 0805	R36, R37, R38	SMEC, RC73L2A105JT
1	9.53K Ω , 1%, 0805	R39	SMEC, RC73L2A9531FT
1	4.02K Ω , 1%, 0805	R40	SMEC, RC73L2A4021FT
1	33.2K Ω , 1%, 0805	R41	SMEC, RC73L2A3322FT

Qty	Description	Ref. Designators	Vendor Part #
2	12.1K Ω , 1%, 0805	R42, R43	SMEC, RC73L2A1212FT
3	100K Ω , 1%, 0805	R44, R45, R46	SMEC, RC73L2A1003FT
1	150K Ω , 1%, 0805	R47	SMEC, RC73L2A1501FT
3	6.98K Ω , 1%, 0805	R48, R49, R50	SMEC, RC73L2A6981FT
3	2.49K Ω , 1%, 0805	R51, R52, R53	SMEC, RC73L2A2491FT
3	5.49K Ω , 1%, 0805	R54, R55, R56	SMEC, RC73L2A5491FT
3	680 Ω , 5%, 0805	R63, R64, R65	SMEC, RC73L2A681JT
3	1K Ω , 5%, 0805	R66, R67, R68	SMEC, RC73L2A102JT
5	470 Ω , 5%, 0805	R58, R59, R60, R 61, R62 (Optional)	SMEC, RC73L2A471JT
1	0.200 Ω , 1%, 3W	R57	OHMITE, 13FR200
Inductors			
2	FERRITE BEAD,	L1, L2	Panasonic, EXC-ELSA35V
LEDs			
1	Green LED, 1206	LED1	Agilent, HSMG-C650
2	Red LED, 1206	LED2, LED5 (Optional)	Agilent, HSMS-C650
1	Yellow LED, 1206	LED3 (Optional)	Agilent, HSMY-C650
2	Green LED, 1206	LED4, LED6 (Optional)	Agilent, HSMG-C650
Diode			
2	S2B-FM401, SMA	D1, D2	Vishay, DL4001DICT

Qty	Description	Ref. Designators	Vendor Part #
Capacitors			
1	470 μ F, 25VDC, ELECT-G	C1	Panasonic, EEV-FC1C471P
2	47 μ F, 16VDC, ELECT-C	C2, C3	Panasonic, ECE-V1CA470WR
3	10 μ F, 16VDC, ELECT-B	C4, C5, C6	Panasonic, EEV-FC1C100R
7	0.1 μ F, 0805	C7, C8, C9, C10, C11, C12, C13	SMEC, MCCE104K2NRT
6	100pF, 0805	C14, C15, C16, C25, C26, C27	SMEC, MCCE101J2NOT
3	22pF, 0805	C17, C18, C19	SMEC, MCCE220J2NOT
3	470pF, 0805	C20, C21, C22	SMEC, MCCE471J2NOT
2	33pF, 0805	C23, C24	SMEC, MCCE330J2NOT
3	0.01 μ F, 0805	C28, C29, C30	SMEC, MCCE104K2NRT
Test Points			
1	+3.3V Test Point	TP1	KEYSTONE, 5000, RED
1	GND Test Point	TP2	KEYSTONE, 5001, BLACK
Connectors			
1	40x2 Header	P1	SAMTEC, TSW-140-07-S-D
1	2.1mm Power Connector	P2	Switchcraft, RAPC-722
1	Motor FPC Connector	J1	MOLEX, 52207-1190
1	3x3 Header	JG1	SAMTEC, TSW-103-07-S-T
1	7x2 JTAG Header	J1	SAMTEC, TSW-107-07-S-D
Transistors			
3	N-Channel MOSFET	Q1, Q2, Q3	International Rectifier, IRLML6402
3	P-Channel MOSFET	Q4, Q5, Q6	International Rectifier, IRLML2502
3	General Purpose NPN Transistor	Q7, Q8, Q9	SMEC, MMBT2222A
Miscellaneous			
4	Stand-off Post, 4-40		Aluminum 0.25" Hex Female, 0.375"
4	4-40 Screws		SAE 4-40 machine screw, 0.375"
3	Shunt		Samtec, SNT-100-BL-T

56F8000 Motor Control Bill of Material, Rev. 0

INDEX

A

A/D [1-ix](#)
 ADC [1-ix](#)
 Analog-to-Digital
 A/D [1-ix](#)
 Analog-to-Digital Converter
 ADC [1-ix](#)

D

Debugging [2-6](#)

E

Enhanced On-Chip Emulation
 EOnCE [1-ix](#)
 EOnce [1-ix](#)
 Evaluation Module
 EVM [1-ix](#)
 EVM [1-ix](#)

G

General Purpose Input and Output
 GPIO [1-ix](#)
 GPIO [1-ix](#)

I

IC [1-ix](#)
 Integrated Circuit
 IC [1-ix](#)

J

Joint Test Action Group
 JTAG [1-ix](#)
 JTAG [1-ix](#)

L

LED [1-ix](#)
 Light Emitting Diode
 LED [1-ix](#)

O

OnCE [1-ix](#)
 On-Chip Emulation
 OnCE [1-ix](#)

P

PCB [1-ix](#)
 Printed Circuit Board
 PCB [1-ix](#)
 Pulse Width Modulation
 PWM [1-ix](#)
 PWM [1-ix](#)

R

real-time debugging [2-6](#)

How to Reach Us:

Home Page:

www.freescale.com

E-mail:

support@freescale.com

USA/Europe or Locations Not Listed:

Freescale Semiconductor
Technical Information Center, CH370
1300 N. Alma School Road
Chandler, Arizona 85224
+1-800-521-6274 or +1-480-768-2130
support@freescale.com

Europe, Middle East, and Africa:

Freescale Halbleiter Deutschland GmbH
Technical Information Center
Schatzbogen 7
81829 Muenchen, Germany
+44 1296 380 456 (English)
+46 8 52200080 (English)
+49 89 92103 559 (German)
+33 1 69 35 48 48 (French)
support@freescale.com

Japan:

Freescale Semiconductor Japan Ltd.
Headquarters
ARCO Tower 15F
1-8-1, Shimo-Meguro, Meguro-ku,
Tokyo 153-0064, Japan
0120 191014 or +81 3 5437 9125
support.japan@freescale.com

Asia/Pacific:

Freescale Semiconductor Hong Kong Ltd.
Technical Information Center
2 Dai King Street
Tai Po Industrial Estate
Tai Po, N.T., Hong Kong
+800 2666 8080
support.asia@freescale.com

For Literature Requests Only:

Freescale Semiconductor Literature Distribution Center
P.O. Box 5405
Denver, Colorado 80217
1-800-441-2447 or 303-675-2140
Fax: 303-675-2150
LDCForFreescaleSemiconductor@hibbertgroup.com

Information in this document is provided solely to enable system and software implementers to use Freescale Semiconductor products. There are no express or implied copyright licenses granted hereunder to design or fabricate any integrated circuits or integrated circuits based on the information in this document.

Freescale Semiconductor reserves the right to make changes without further notice to any products herein. Freescale Semiconductor makes no warranty, representation or guarantee regarding the suitability of its products for any particular purpose, nor does Freescale Semiconductor assume any liability arising out of the application or use of any product or circuit, and specifically disclaims any and all liability, including without limitation consequential or incidental damages. "Typical" parameters that may be provided in Freescale Semiconductor data sheets and/or specifications can and do vary in different applications and actual performance may vary over time. All operating parameters, including "Typicals", must be validated for each customer application by customer's technical experts. Freescale Semiconductor does not convey any license under its patent rights nor the rights of others. Freescale Semiconductor products are not designed, intended, or authorized for use as components in systems intended for surgical implant into the body, or other applications intended to support or sustain life, or for any other application in which the failure of the Freescale Semiconductor product could create a situation where personal injury or death may occur. Should Buyer purchase or use Freescale Semiconductor products for any such unintended or unauthorized application, Buyer shall indemnify and hold Freescale Semiconductor and its officers, employees, subsidiaries, affiliates, and distributors harmless against all claims, costs, damages, and expenses, and reasonable attorney fees arising out of, directly or indirectly, any claim of personal injury or death associated with such unintended or unauthorized use, even if such claim alleges that Freescale Semiconductor was negligent regarding the design or manufacture of the part.



Freescale™ and the Freescale logo are trademarks of Freescale Semiconductor, Inc. All other product or service names are the property of their respective owners. This product incorporates SuperFlash® technology licensed from SST.

© Freescale Semiconductor, Inc. 2005. All rights reserved.