



S32K376 Battery Management System (BMS) and Vehicle Control Unit (VCU) PoC Design

S32K376POC

Last Updated: Apr 25, 2024

The NXP S32K376 Battery Management System (BMS) and Vehicle Control Unit (VCU) proof of concept design is a demonstration of an integrated, one box Electronic Control Unit (ECU) solution.

The BMS system monitors battery voltage, temperature, fault status, among others and the VCU system samples simulated pedal position, gear, sensors, among others. Software is developed based on NXP's [Real-Time Drivers \(RTD\)](#).

This PoC is intended to provide a mechanism for easy customer evaluation of the S32K37 electrification MCU and to facilitate BMS and VCU hardware and software development. Additionally, Over-the-air (OTA) and bootloader functions are also integrated into the software package, enabling in-field program updates. The [FS26 Automotive Safety Basis Chip \(SBC\)](#) is used for power management and monitoring.

Note: The actual hardware uses a 100% hardware and software compatible superset MCU S32K396.

S32K376 BMS and VCU PoC hardware Block Diagram

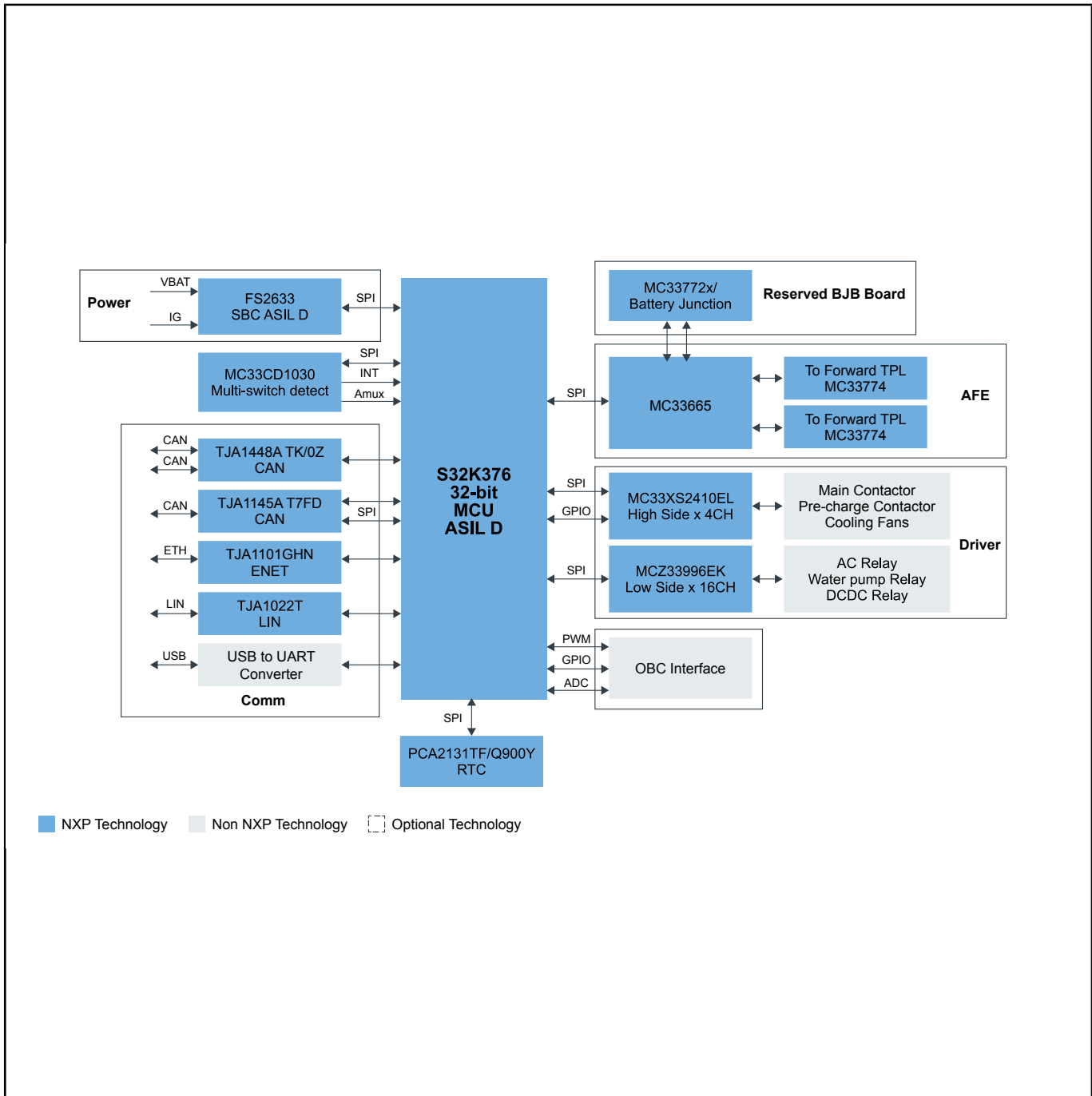

BMS Total Block Diagram

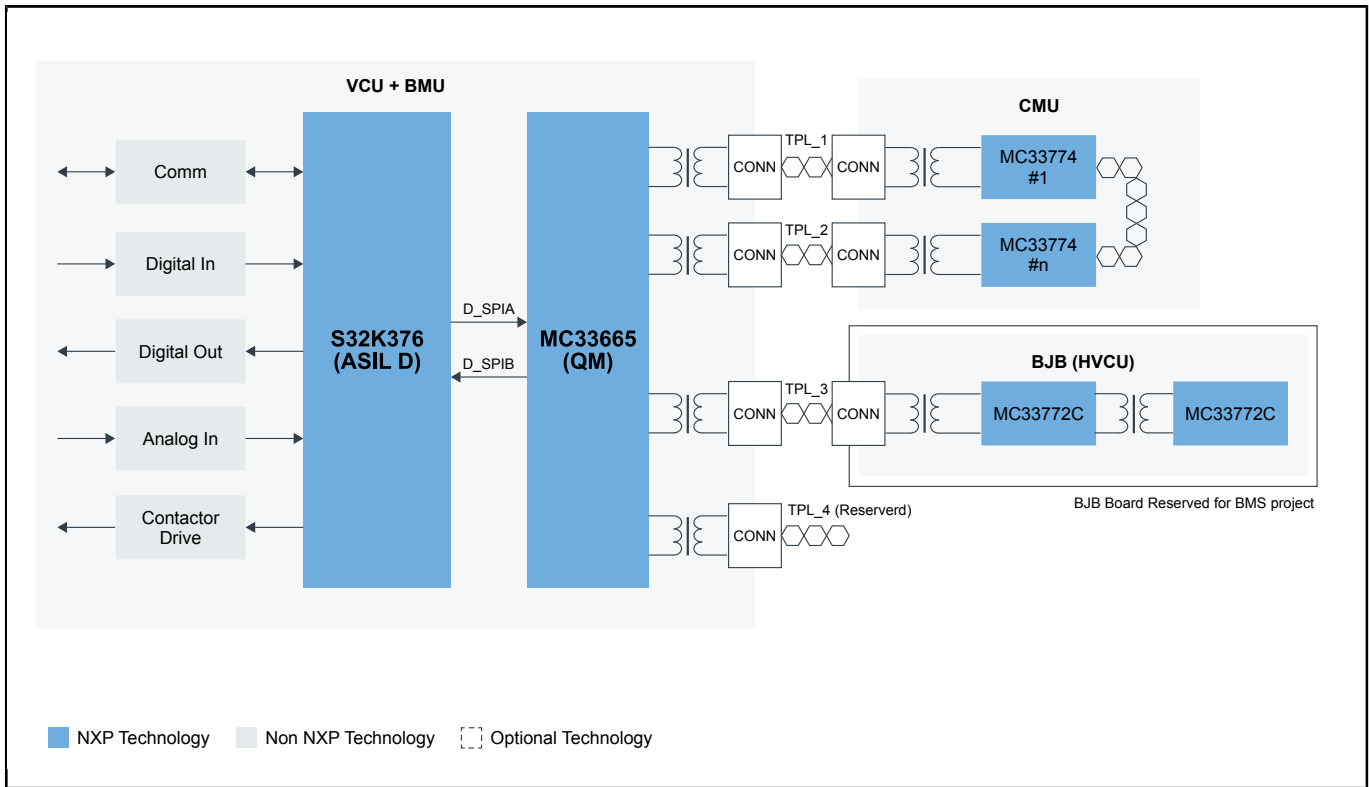

View additional information for [S32K376 Battery Management System \(BMS\) and Vehicle Control Unit \(VCU\) PoC Design](#).

Note: The information on this document is subject to change without notice.

www.nxp.com

NXP and the NXP logo are trademarks of NXP B.V. All other product or service names are the property of their respective owners. The related technology may be protected by any or all of patents, copyrights, designs and trade secrets. All rights reserved. © 2024 NXP B.V.