



# NTAG<sup>®</sup> SmartSensor with Temperature Sensor, Digital and Analog IOs

## NHS3152

Last Updated: Aug 17, 2023

The NXP<sup>®</sup> NHS3152 is an IC optimized for logging and sensing. With its embedded NFC interface, internal temperature sensor, ADC, DAC, current sensor, and direct battery connection, it supports an effective system solution with a minimal number of external components.

The embedded Arm<sup>®</sup> Cortex<sup>®</sup>-M0+ offers flexibility to the users of this IC to implement their own dedicated solution. The NHS3152 contains multiple features, including multiple Power-down modes and a selectable CPU frequency of up to 8 MHz, for ultra-low-power consumption.

Users can program this NHS3152 with the industry-wide standard solutions for Cortex-M0+ processors.

# NHS3152 Block Diagram Block Diagram

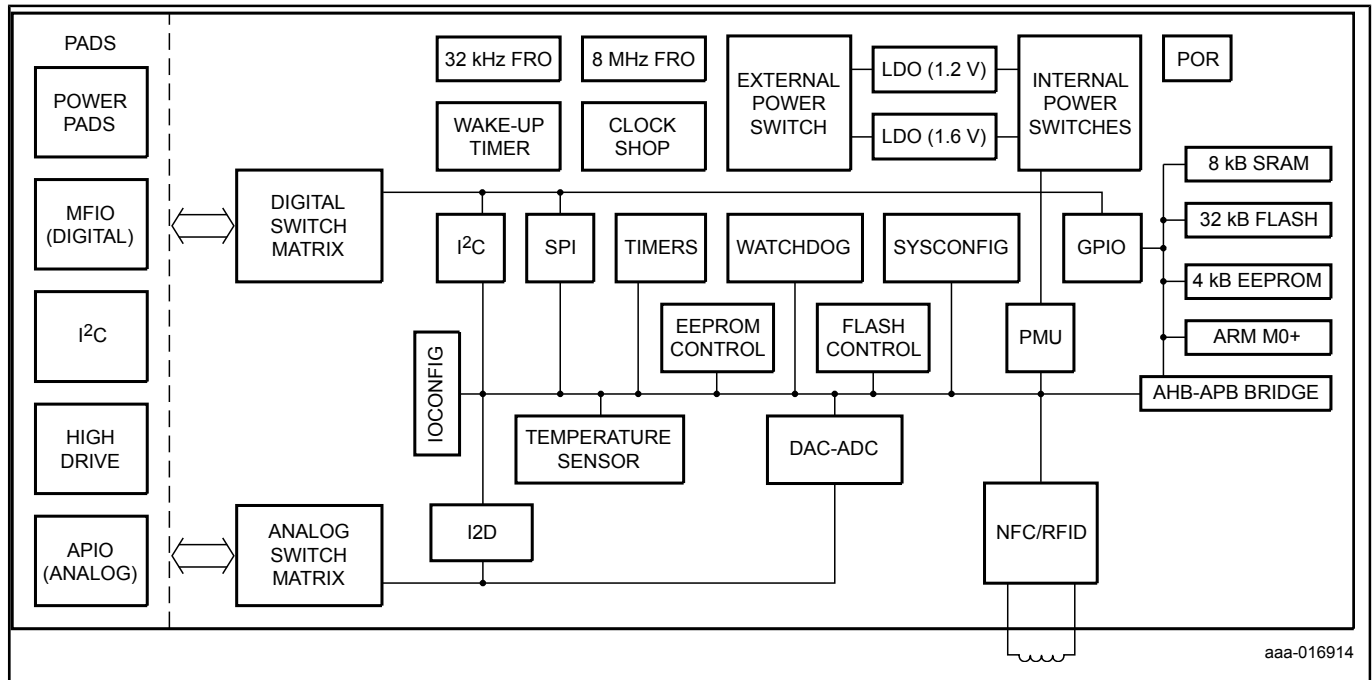

View additional information for [NTAG® SmartSensor with Temperature Sensor, Digital and Analog IOs](#).

**Note:** The information on this document is subject to change without notice.

[www.nxp.com](http://www.nxp.com)

NXP and the NXP logo are trademarks of NXP B.V. All other product or service names are the property of their respective owners. The related technology may be protected by any or all of patents, copyrights, designs and trade secrets. All rights reserved. © 2024 NXP B.V.